

2

1

REV	CO#	DESCRIPTION	NAME	DATE
A	001	Initial Release	DW	8/10/16
B	002	Increased width of hub to improve machining. Tightened tolerance on center rivet hole. Increased size of ROM channel, moved channel away from edge of part. Added radius to box interaction. Added radius to transition from round to square geometry. Added width to interaction with the box hub and material extension onto circular region. Added length to neck.	DW	11/30/16

B

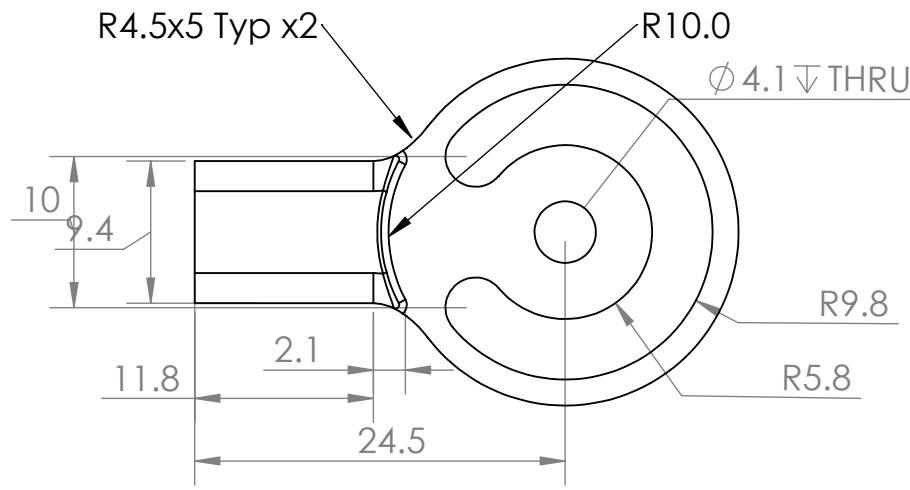

B

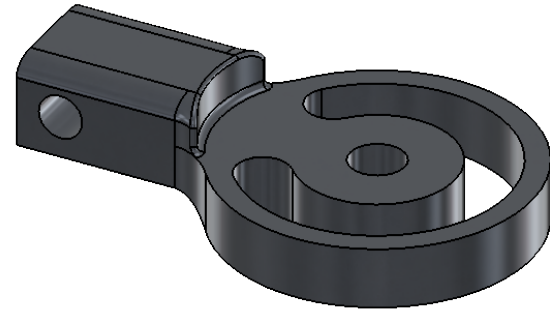

A

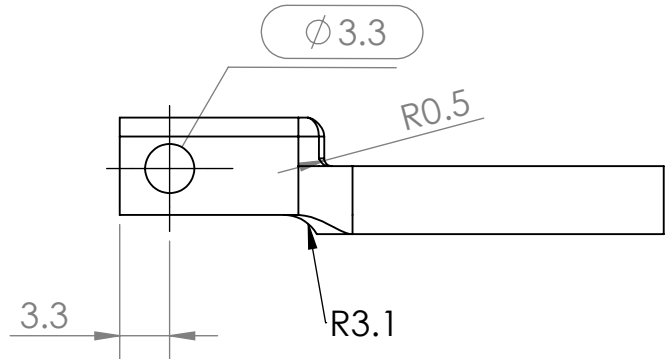

A

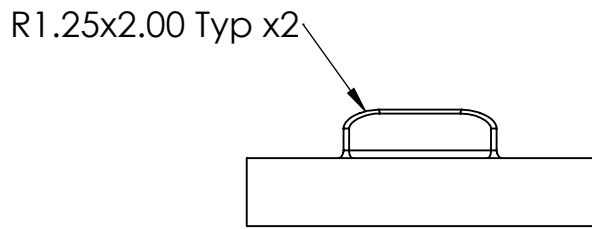

ALL DIMENSIONS IN MILLIMETERS UNLESS OTHERWISE NOTED 0.1 ± 0.1 0.01 ± 0.01 0.001 ± 0.001	
PART NAME: Medium Hub - Guide	
REV: B	
P/N: C003-06	
DRAWN BY: D. Wenzel	
DATE: 11/29/16	
2:1	Aluminum 6061 - Anodized



2

1