

2

1

REV	CO#	DESCRIPTION	NAME	DATE
A	001	Initial Release	DW	8/10/16
B	002	Increased width of hub to improve machining. Tightened tolerance on center rivet hole. Increased size of ROM holes, decreased the number. Moved ROM holes away from the edge of the part. Added radius to box interaction. Added radius to transition from round to square geometry. Added width to box interaction, added material over round portion of hub.	DW	10/20/16

B

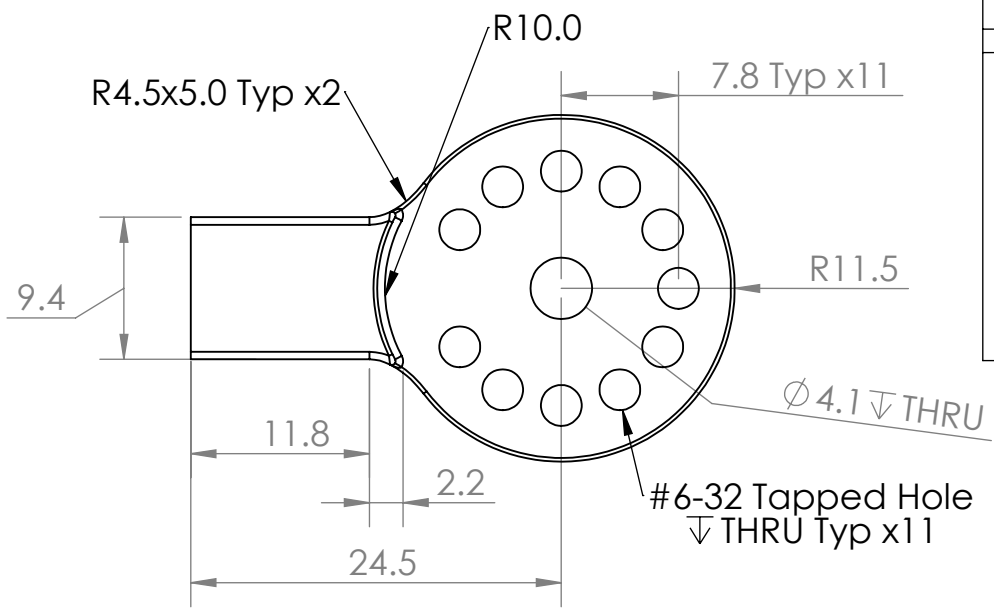

B

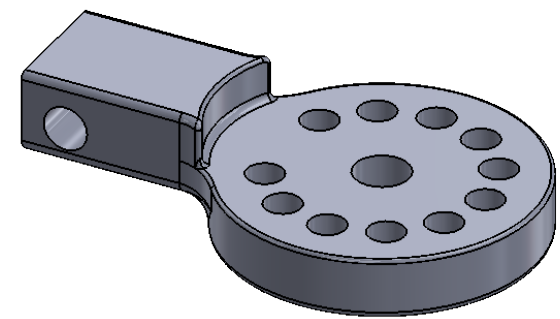

A

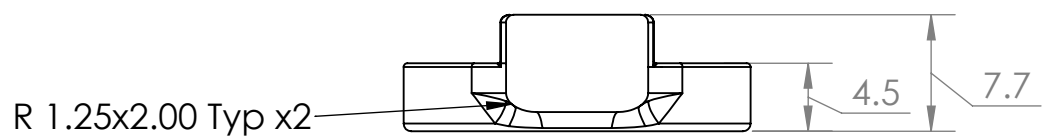
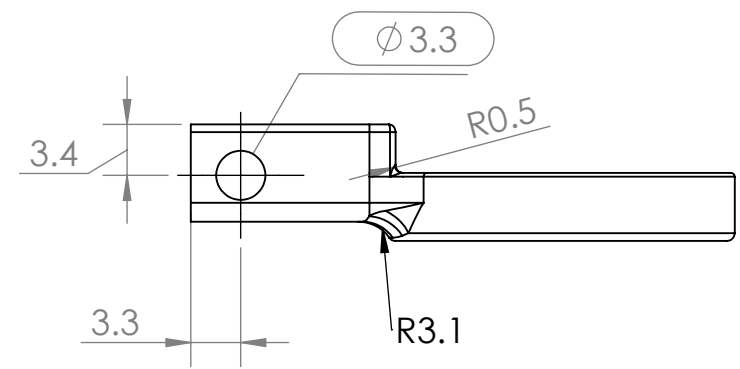

A

ALL DIMENSIONS IN MILLIMETERS UNLESS OTHERWISE NOTED 0.1 ± 0.1 0.01 ± 0.01 0.001 ± 0.001			
PART NAME: Medium Hub - Holes		REV: B	
P/N: C003-07		DATE: 11/29/16	
DRAWN BY: D. Wenzel		2:1	
Aluminum 6061 - Anodized			

2

1

