

2

1

B

B

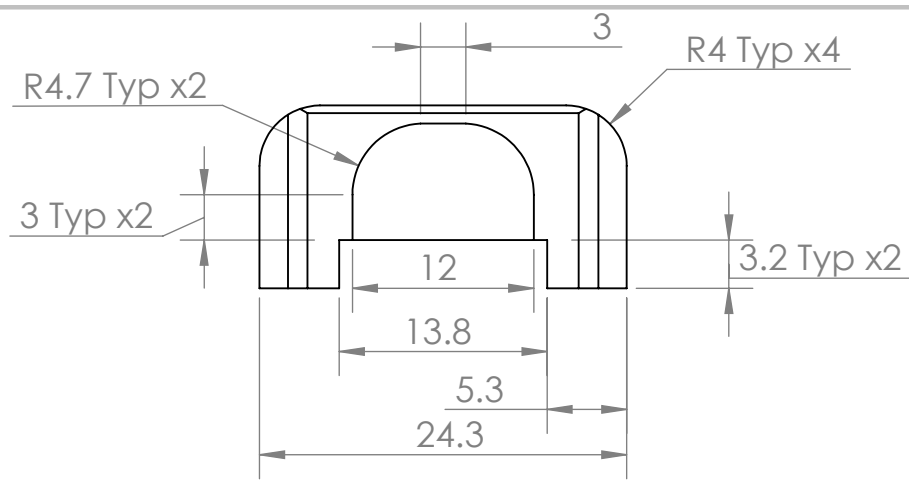

REV	CO#	DESCRIPTION	NAME	DATE
A	001	Initial Release	DW	8/10/16
B	002	Increased overall width and length to increase durability. Increased size of dowel pin interaction to accept 3/4" long dowel pin instead of 1/2" dowel pin. Increased opening for hub interaction. Added chamfers and fillets on box corners.	DW	10/20/16

A

A

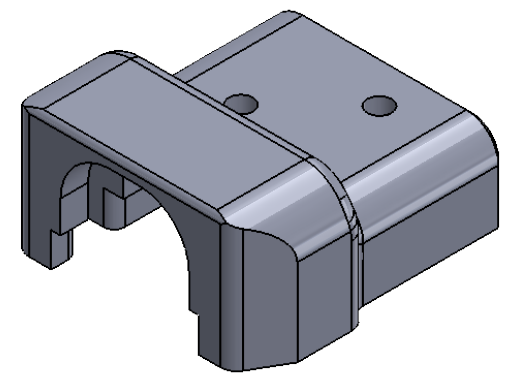
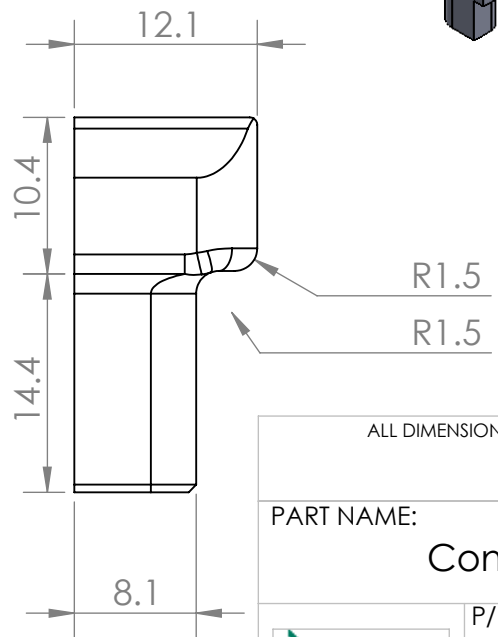
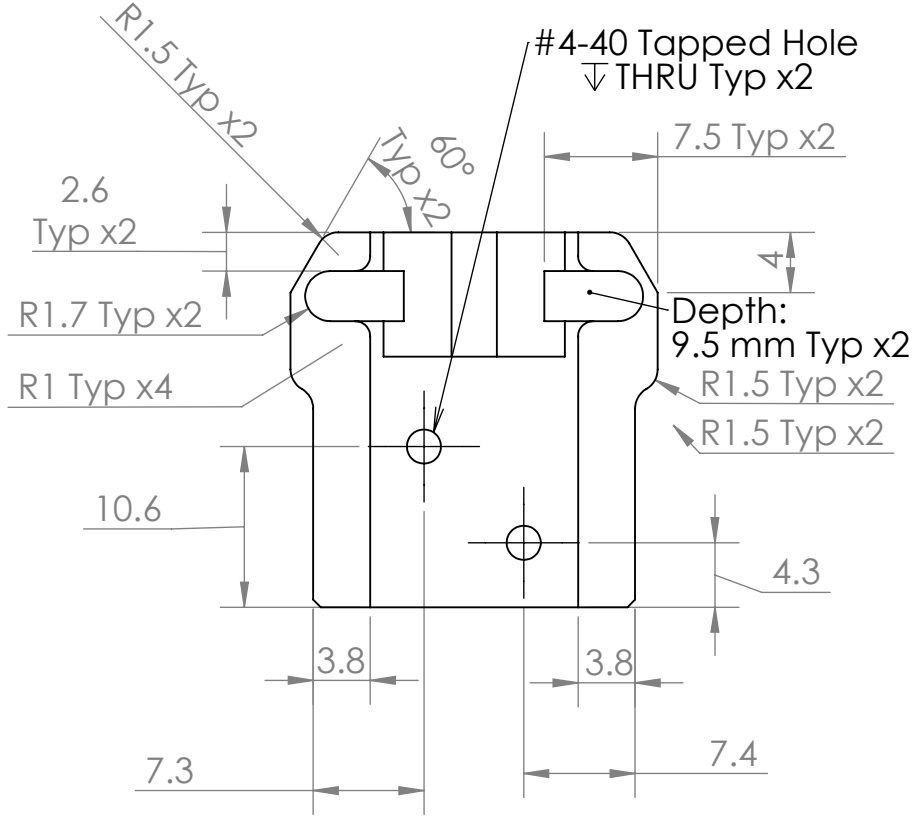

ALL DIMENSIONS IN MILLIMETERS UNLESS OTHERWISE NOTED
 0.1 ± 0.1
 0.01 ± 0.01
 0.001 ± 0.001

PART NAME: Connector Box		REV: A+
P/N: C003-08		DATE: 11/29/16
DRAWN BY: D. Wenzel		
2:1		Aluminum 6061 - Anodized



2

1